

KN2C 2020M USER MANUAL

Rev.1-2





Table of Contents

General	3
Specifications.....	3
Multi Display	4
Contents in the package	5
Prepare to use	6
Assemble Main Unit	6
Connect Cables.....	7
After Assembly the kit.....	8
Connection Diagram.....	9
The Antenna Unit	10
Wideband Principles	9
FM Receiver	10
The GPS RS232 Input Port	11
DF Calibration	11
Preparing Calibration.....	11
Calibration	12
Q & A	12



THE STEALTH
KN2C2020M/GPS

The **KN2C 2020M** DF is an economical but very sophisticated Doppler DF "kit" with a GPS input, and RS232 output to provide the ability to indicate its location and draw bearing automatically or manually on Google Earth map to find the RF transmitter more conveniently.

KN2C 2020M kit Includes eight assembled / tested PC boards: MAIN board, 2 Sub boards, and 1 antenna board in the main unit. Completion work is required by the user to finish the DF main unit. Guidelines for the completion work are provided.

The user must provide a NB FM receiver, antennas and a PC for DF bearing (Windows OS). DDF2020 display program further requires a GPS receiver with NMEA 4800 baud output.

- VHF Doppler DF – 5 Antennas primarily for mobile DF, 100~1000 MHz
- Economy, high performance DSP / micro processor design, software intensive
- Sold as a kit – Main unit, antenna unit and associated cables
- Accepts **NMEA RS232** GPS input data (4800 baud, \$GPRMC, \$GPGGA and / or \$GPVTG sentences) for "Plotting map on Windows PC display"
- RS232 output for Windows PCs (Agrello format)
- Uses modified **Joe Moell Wideband Antenna** design
- 9 ~ 28 VDC operation
- Optional **GPS Receiver** available

Specifications:

Rcvr Freq: Determined by user-provided FM receiver (Range 100 to 1000 MHz)

Antenna: Four elements for DF and one auxiliary element for improving sensitivity and accuracy, (Wave vertical with assembled)

Ant Scan: Scan rate 430 Hz, rotation clockwise (viewed from above antenna)

Ant Switch: Modified **Joe Moell Wideband Doppler DF antenna** design

Employs **Agilent HSMP3893** SMT PIN diodes

SMT / strip line circuit design, **SMA** output connector

Audio Input: FM receiver speaker audio, 1.0K ohm load. 25db dynamic range.

GPS Input: 4800 baud RS232 input, NMEA \$GPRMC, \$GPGGA and / or \$GPVTG messages.

Output 1: RS232 Agrello DF message, 4800 baud, 8N2. (15 messages / second)

Ant Outputs : Four discrete active HIGH outputs for **KN2C 2020** Antenna (one per antenna)

DC Power : 9 ~ 28 VDC



Global TSCM Group, Inc.

12 W 32nd St, Suite 604, New York, NY 10001, USA
<http://globaltscmgroup-usa.com> sales@globaltscmgroup-usa.com
Tel.: +1 212 967 4030 +1 646 233 0383 Fax: +1 212 967 7560

THE STEALTH
The Confidential Catch

Voice Filter : Switched-capacitor filter, (SCF) 4 sections. Bandwidth 0.2 Hz

Multi Display

The **MultiDisplay** of **KN2C 2020M** provides a combined numeric and pelorus display in the main board. A high quality display, with 2 microcomputers and an RS232 input that accepts Agrello DF messages.

The pelorus display employs 36 high density LEDs, with 4 yellow LEDs at cardinal headings. Option straps allow "hold/blink" of last valid DF data, or pelorus "orbit" when data goes invalid. All LEDs briefly "flash" (2 second intervals) for enhanced nighttime viewing

- 3 digit numeric readout, 0.36 inch characters
- 36 LED pelorus display, 4 yellow cardinal LEDs
- Selectable HOLD/ORBIT display for old DF data
- Power-on self-test

RS232 Output

The RS232 output message is transmitted about 10 times per second, and complies with the (very popular) **Agrello DF** message format, as shown below :

Agrello DF message format :

%BBB/Q<cr>

Where **%** = message start character

 BBB = signal bearing degrees (000-359)

 Q = signal quality (0-9) (fixed @ 7 in this design)

 <cr> = carriage return

The RS232 message is transmitted at 4800 baud, with an 8N2 byte format. Negative voltage for the RS232 port is "robbed" from the host computer's TX line, which is (otherwise) ignored.

The appearance and specifications can be changed without ant notification for the purpose of upgrade product.

Contents in the package

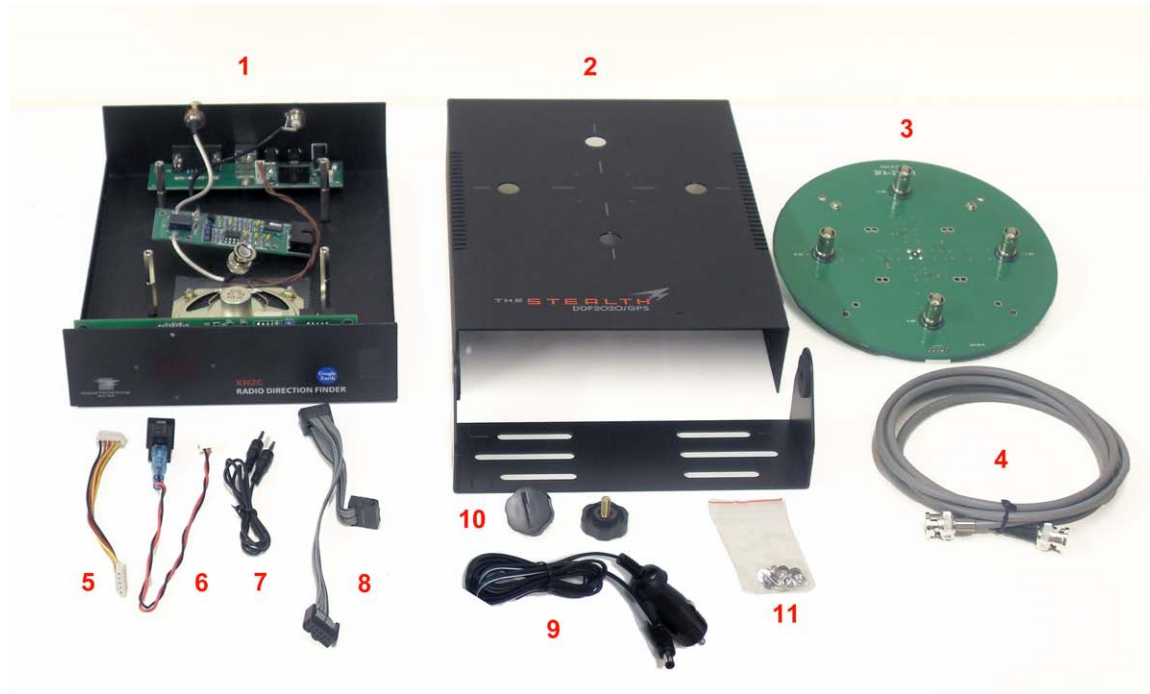

1. Case with assembled parts - requires a minimum assembly
2. Upper panel
3. Antenna Board
4. Antenna cable (DDF2020M to FM Receiver – 2 BNC Jacks)
5. Antenna Board Cable
6. Power Switch
7. 3.5 mm Audio Cable Set
8. Main Cable
9. Cigar Jack Power Cord
10. Bracket and Screws
11. Screw pack

Prepare to use

1) Assemble Main Unit

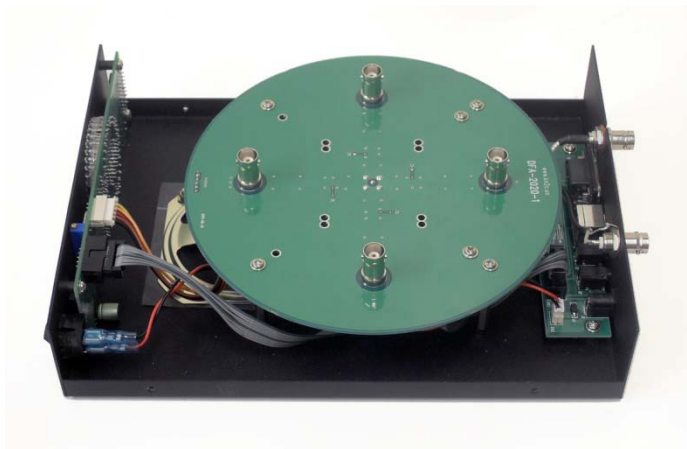
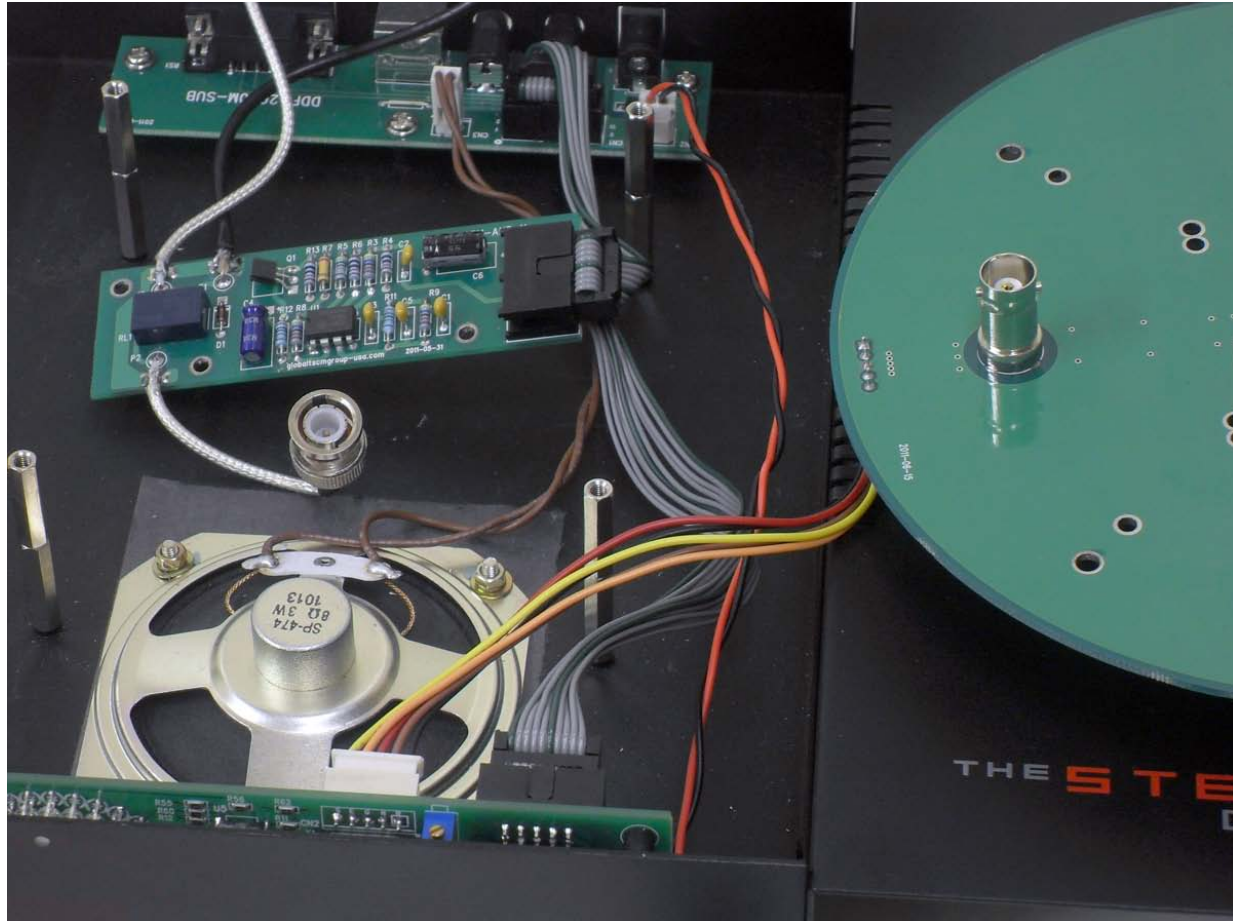

The appearance and specifications can be changed without ant notification for the purpose of upgrade product.

- a) Put Front Decal on the front of case – Begin right side (Power switch hole) first.
- b) Plug the power switch into the hole – Push it until its clamps hold the case.
- c) Connect the switch on the sub board.
- d) Connect the main cable and antenna board cable
- e) Assemble Antenna Board with 4 screws on antenna poles
- f) Cover with Upper Panel and fasten it with screws
- g) Attach the bracket if necessary.

2) Connect Cables



- a) DC(9-28V) : Main Power – Cigar Jack cable or DC adaptor
- b) PHONE : Connect earphone or external speaker if necessary
- c) AUDIO IN: Connect audio output from a receiver with 3.5 mm Audio Cable provided
- d) GPS: Connect the optional GPS receiver (4800 BPS)
- e) RS-232: Connect a PC for plotting on Google Earth map
- f) ANT – Connect to FM Receiver's antenna BNC connector
- g) DF ANT 1~4 – Connect external DF antennas
- h) ANT5 – Connect 5th Auxiliary antenna

3) After Assembly the kit (Example)

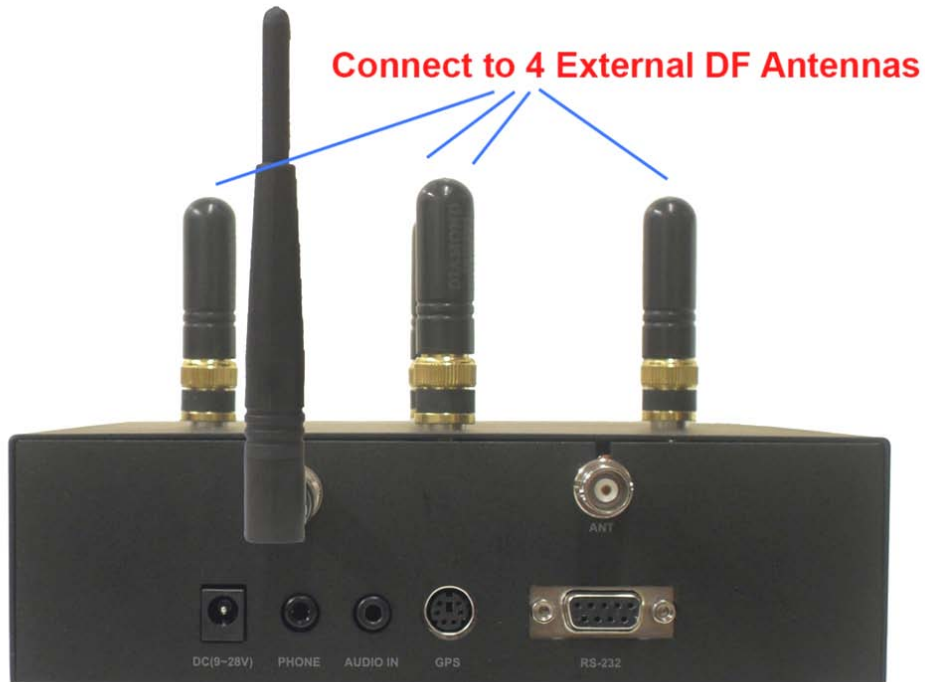

External DF Antennas (Example)

4) KN2C 2020M Connection Diagram

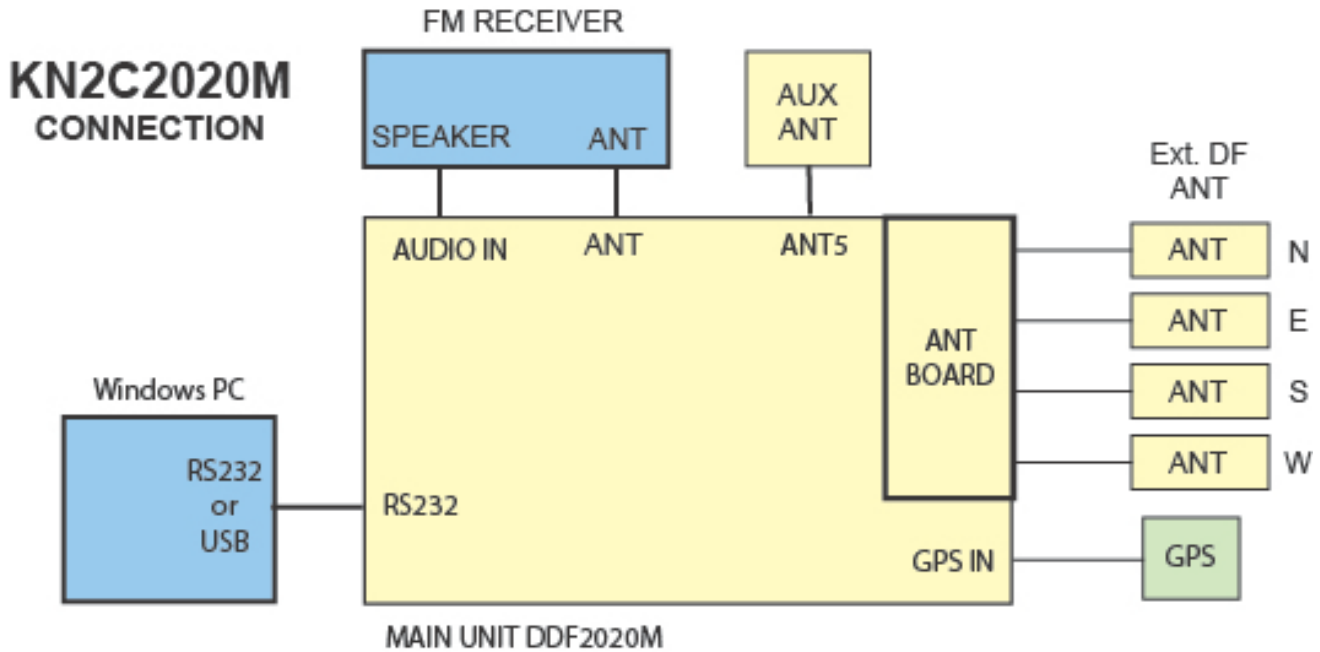

- ❖ When you use RS232(Serial) To USB Converter, please install the right driver comes with it.
- ❖ Antenna N should be placed in frontward of vehicle to indicate 0 degree of DF.Display.
- ❖ When KN2C 2020 tunes with the right RF signal, it outputs clear 430 Hz audio signal which will indicates stable LED.

GPS631

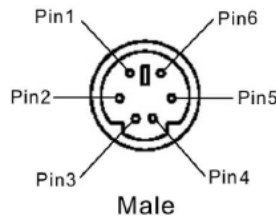

Pin	Name	I/O	Description
1	TX(RS232)	O	Transmitter of RS232 logic level
2	NC	-	No connection
3	VDD	P	Power supply of 5V input
4	GND	P	Ground
5	RX(RS232)	I	Receiver of RS232 logic level
6	NC	-	No connection

The DF Antennas

1) Wideband Principles

- a) The **KN2C 2020M** antenna board described here should be suitable for use across multiple octaves of frequency range. The **KN2C 2020M** antenna board is intended for use across the range of 100 MHz to 1 GHz, but operation outside these limits can reasonably be expected, and the exact limits can only be determined experimentally. RF sensitivity of the antenna is another matter. Sensitivity will vary significantly with large frequency changes, but this can be compensated to some degree by using antenna elements of different length for specific bands. The information provided below is intended for people who anticipate using the **KN2C 2020M** across a multi-octave frequency range.
- b) The upper frequency limit of operation for a Doppler antenna is fairly well-defined, and is determined by the separation distance between adjacent antenna elements, expressed in wavelengths. Distances exceeding $1/3$ wavelength will begin to degrade the RF sensitivity of the antenna, and distance of wavelength will definitely cause trouble. The reason involves the amount of RF phase "jump" that occurs when the DF switches from one antenna to the next. The receiver must "adjust" to the changes of (input) RF phase, and the Doppler pulses are created in the receiver as a "side effect" of the re-adjustment process.
- c) For phase jumps exceeding 120 degrees, (= $1/3$ wavelength distance) the amplitude of the RF signal will suffer some decay while the receiver "re-adjusts" to the new RF phase angle. For phase jumps of 180 degrees (= wavelength distance) the RF signal will completely decay to zero amplitude, and then "re-appear" in the receiver, (with reversed phase) resulting in a "noise" pulse instead of a Doppler pulse.
- d) The lower frequency limit is more nebulous and ill-defined. Strictly speaking, there is no true lower frequency "limit" for the operation of a Doppler. As the RF frequency descends, the size of the antenna (expressed in wavelengths) grows progressively smaller, yielding Doppler pulses of progressively smaller amplitude. The relationship is quite predictable and linear cutting the RF frequency in half will cut the Doppler pulses in half also. (because the antenna dimensions have been cut in half, expressed in wavelengths)
- e) This can be compensated (to some degree) by increasing the audio level in the receiver, but there is a limit to this method at some point, the audio level will be so great that serious distortion will result, either in the Doppler input circuits or in the audio output stages of the receiver. Therefore, the factors that determine the lower frequency limit are (1) The size of the antenna, expressed in wavelengths, (2) the maximum audio level that will not cause distortion, and (3) the minimum detection level of the Doppler DF.

2) Installing DF antennas

- a) The each of 4 DF ANTENNA must be connected to each BNC connector on antenna board with a short length of coaxial cable. The length of these 4 cables is not critical, but all must be of equal length, within 1 inch. The shield for these cables operates about 1 volt DC above vehicle ground, so do not allow them to make contact with vehicle ground, at either end of the cable.
- b) The antenna is usually 12 to 18 inches long, but never greater than $1/4$ wavelength of frequency.
- c) The DF antennas must be arranged into a square, with all sides of the square being of equal length, within 1 inch, and the size of the square should never exceed $1/4$ wavelength on any side.

The FM Receiver

- 1) When installed, the antenna input of the FM receiver is connected via a coaxial cable to the BNC connector located on the main antenna module of **KN2C 2020M**. The FM receiver speaker output is connected to the **KN2C 2020M** audio input.
- 2) The **KN2C 2020M** DF requires a FM receiver, which the user must provide. This receiver determines the operating frequency for the DF (DF radio channel). The receiver must be a FM receiver, because Doppler shift is a form of frequency shift, so the receiver's detector must be a "frequency shift detector" (FM detector) to recover the Doppler signal.
- 3) The intended operating range of the Kn2c 2020 DF is 100 to 1000 MHz, but reasonable operation beyond these limits can be expected, with a suitable antenna unit.

The appearance and specifications can be changed without ant notification for the purpose of upgrade product.



Global TSCM Group, Inc.

12 W 32nd St, Suite 604, New York, NY 10001, USA
<http://globaltscmgroup-usa.com> sales@globaltscmgroup-usa.com
Tel.: +1 212 967 4030 +1 646 233 0383 Fax: +1 212 967 7560

THE STEALTH
The Confidential Catch

- 4) No internal modifications to the FM receiver are required. The Doppler modulation (caused by the antenna switching) results in an audio "tone" or "whine" that is detected along with any "voice" audio in the received signal. The frequency of the Doppler tone is about 430 Hz, and it passes easily through the audio circuits of the FM receiver, just like any other audio tone.

The GPS RS232 Input Port

The GPS RS232 input accepts 4800 baud NMEA data, scans the data for the \$GPRMC, \$GPGGA and \$GPVTG sentences, (very common) and relays these sentences (if found) through the **KN2C 2020M** RS232 output port, to the display computer. GPS Data is NOT fed to the IR port. To increase the amount of DF data provided, every 3rd GPS message is relayed, instead of each message. Furthermore, only the \$GPRMC message is relayed, if found. Otherwise, the \$GPGGA and \$GPVTG messages are relayed, if found.

The GPS itself must generally be configured to transmit NMEA data, because a variety of data formats are available. (NMEA is the most common format) In some cases, it will be necessary to buy a special cable from the manufacturer, to get the data. The \$GPRMC, \$GPGGA and \$GPVTG sentences are the most common NMEA sentences provided, but if you wish to confirm their presence in your GPS output, you can examine the data stream with HyperTerminal, which is provided (free) with every Windows operating system, in the PROGRAMS / ACCESSORIES menu.

If you do not wish to employ the GPS input, simply leave it disconnected

DF Calibration

Calibration DF unit will be necessary at the first time or any time you use your KN2C 2020 on a different vehicle.

It is necessary to recalibrate, if you remove and replace the antennas on your vehicle, and they are not placed back in precisely the same locations and geometry making.

Installing the antenna unit on the roof of your vehicle

- a. Place N on the frontward of car (0 degree)
- b. Place S to on the backward of car (180 degree)
- c. Place E to on the passenger side of car (90 degree)
- d. Place W to on the driver side of car (270 degree)

Preparing Calibration

1. Connect the RF output from the Antenna Control unit to the VHF FM receiver's antenna connector
2. Connect the Antenna Control cable between the Antenna Control unit and KN2C 2020's Main unit.
3. Connect the FM receiver's external speaker audio to the audio input jack on KN2C 2020 main unit.

The appearance and specifications can be changed without ant notification for the purpose of upgrade product.

4. Turn on the power to your DF unit.
5. Turn on the receiver and open the squelch on your receiver, then tune it to the frequency desired.
6. You should hear a 430 Hz tone imposed on any audio present depending on the Antenna Speed selection at startup.

Calibration

The easiest way to calibrate is to drive your vehicle to an open area and have a friend position himself/herself at least 100 ~150 feet (30 ~40 m) away with low power and directly ahead of the vehicle while transmitting an unmodulated carrier.

If your friend is using an HT, ask him/her hold it vertical at approximately the height of the vehicle antennas. If the DDF already turned on, check which direction the direction LED shows and adjust the potential meter through Calibration Hole with a small screw driver. The 0 degree LED should indicate that the signal is directly ahead of the vehicle (N on antenna control unit).

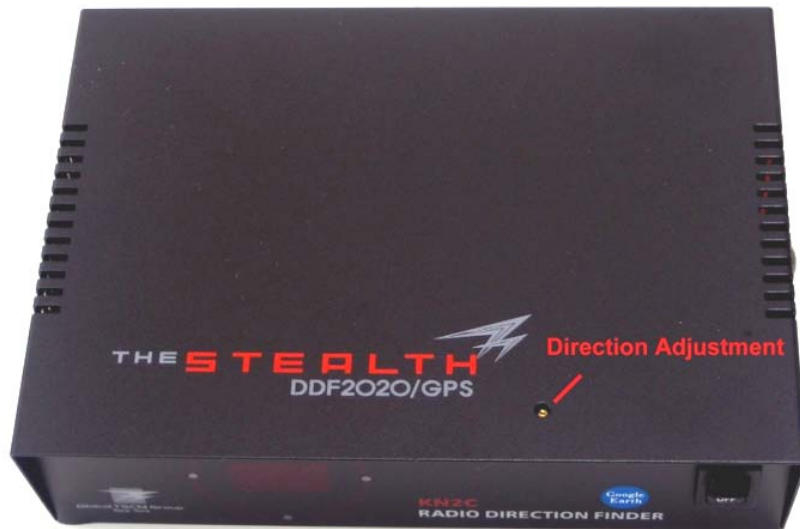

As a double check, your friend can transmit while circling the vehicle at approximately the same distance and the display should follow him/her. The DDF will retain this calibration even after power is turned off.

An alternate method of calibrating the unit is to drive directly towards a known transmitter site, across an open area. This will give you the best calibration but may be difficult or impossible in urban areas. The simpler method should be quite adequate.

You may develop other methodologies that work better in your situation and by all means use them.



Global TSCM Group, Inc.

12 W 32nd St, Suite 604, New York, NY 10001, USA
<http://globaltscmgroup-usa.com> sales@globaltscmgroup-usa.com
Tel.: +1 212 967 4030 +1 646 233 0383 Fax: +1 212 967 7560

THE STEALTH
The Confidential Catch

Q & A

- ❖ I saw a blue LED (0 degree), sometimes unstable red dots, but not beaming the right direction. Sometimes there was a yellow (90, 180, 270 degree) LED.
 - a. Unstable LED means that KN2C 2020 does not receive the right signal. When KN2C 2020 tunes with the right signal, it outputs clear 430 Hz audio signal which will indicate stable LED.
 - b. Adjust the volume of your FM receiver – It may be too low or high
 - c. The transmitter locates too close to DDF antennas
 - d. Check if there are any objects to reflect RF signal such as tall buildings or RF interference
 - e. One of the big reasons for unstable lights is the interference with street objects such as buildings, cars, and trees. The best way to get an accurate bearing is to stop your vehicle at the place to avoid or minimize the interference to draw a bearing and move to another place until you get the satisfied results.

- ❖ The directions of LED look opposite or different angles but seem stable from the actual direction of the transmitter.
 - a. It requires calibration to adjust the angle to the correct direction.
 - b. Check the DF antennas' directions.

- ❖ NAVI 2020 software looks not to receive GPS signal (location information).
 - a. Check whether the external GPS is receiving (blinking red light) and the cable between GPS and the main Unit or the main unit and PC.
 - b. Change COM port.



Global TSCM Group, Inc.

12 W 32nd St, Suite 604, New York, NY 10001, USA

<http://globaltscmgroup-usa.com> sales@globaltscmgroup-usa.com

Tel.: +1 212 967 4030 +1 646 233 0383 Fax: +1 212 967 7560

THE STEALTH
The Confidential Catch

LIMITED WARRANTY

Global TSCM Group, Inc. makes every effort to assure that its products meet high quality and durability standards, and warrants to the original purchaser that this product is free from defects in materials and workmanship for the period of 1 year from the date of purchase. This warranty does not apply to damage due to directly or indirectly, to misuse, abuse, negligence or accidents, repairs or alterations outside our facilities, criminal activity and improper installation.

To take advantage of this warranty, the product or part must be returned with transportation charges prepaid. Proof of purchase date and explanation of the complaint must accompany the merchandise. If our inspection verifies the defect, we will either repair or replace the product at our election. We will return repaired products at our expense, but if we determine there is no defect, or that the defect resulted from causes not within the scope of our warranty, then you must bear the cost of returning the product.